

特性 / FEATURES

- 结构紧凑, 重量轻
Tight structure and light weight
- 高电流容量(载流:35A/10min.25A/1h)
High current contact capacity
(Carrying current: 35A/10min 25A/1h)
- 较高的耐热能力
Improved heat resistance

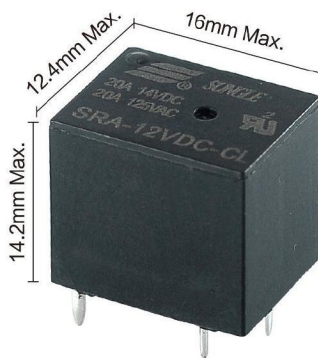

订购信息 / ORDERING INFORMATION

SRA-12VDC-C L

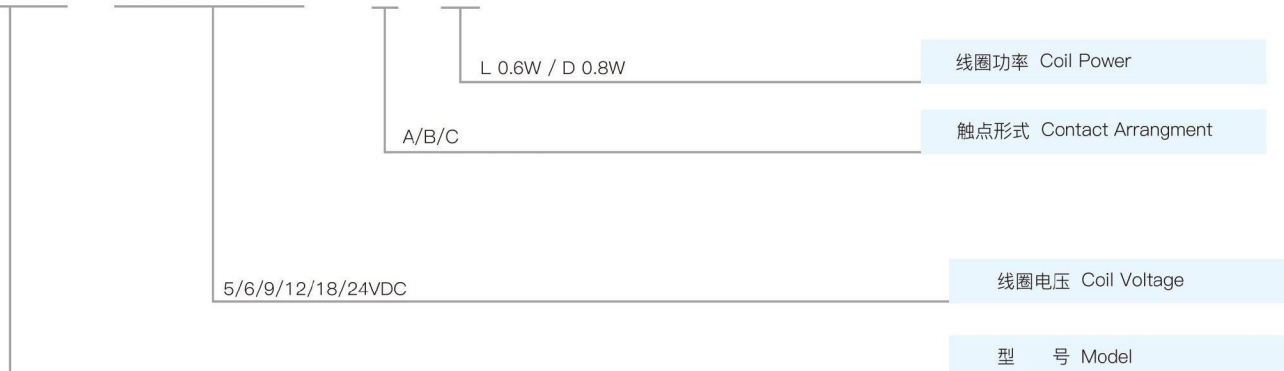

触点参数 / CONTACT PARAMETERS

触点形式	Contact arrangement	A, B, C
接触电阻	Contact resistance	≤100mΩ (1A 6VDC)
触点材质	Contact material	银合金/Silver alloy: AgSnO ₂ In ₂ O ₃ 、AgSnO ₂ 、AgNi
触点负载(阻性)	Contact rating(Res. load)	10A 125VAC, 10A/20A 14VDC
最大切换电压	Max switching voltage	220VAC/16VDC
最大切换电流	Max switching current	常开触点: 35A 常闭触点: 20A
最大切换功率	Max switching power	2200VA/320W
电耐久性 (频率:每小时360次)	Electrical endurance (Frequency:360 ops/h)	1x10 ⁵ ops / 1x10 ⁴ ops
机械耐久性 (频率:每小时18000次)	Mechanical endurance (Frequency:18000 ops/h)	1x10 ⁷ ops

超小型大功率继电器

Subminiature High Power Relay

10A/20A

特性参数 / CHARACTERISTICS PARAMETERS

绝缘等级	Insulation level		B/F
绝缘电阻	Insulation resistance		100MΩ(500VDC)
介质耐压 (漏电流 1mA)	Dielectric strength (Leakage current 1mA)	线圈与触点间 Between coil and contacts	1500VAC 1min
		断开触点间 Between open contacts	1000VAC 1min
吸合时间(额定电压下)	Operate time(at nominal voltage)		≤10ms
释放时间(额定电压下)	Release time (without diode) (at nominal voltage)		≤5ms
湿度	Humidity		5% ~ 85% RH
环境温度(°C)	Ambient temperature		-40°C ~ +85°C/+105°C
抗冲击	Shock resistance	稳定性/Functional	98m/s ²
		强度/Destructive	980m/s ²
抗振动(双振幅)	Vibration resistance (Double amplitude)		10Hz~55Hz 1.5mm
重量	Weight		约/Approx 6g
封装形式	Construction		密封/Sealed 防焊剂/Flux proofed

备注: 以上数据均为初始值

Remark: All above data is initial value

线圈参数 / COIL PARAMETERS

常温/At (23°C)

功耗(W)	Power consumption(W)	0.60W(L)						0.80W(D)					
		05	06	09	12	18	24	05	06	09	12	18	24
额定电压(VDC)	Nominal voltage(VDC)												
线圈电阻(Ω±10%)	Coil resistance(Ω±10%)	42	60	135	240	540	960	31.25	45	101	180	405	720
吸合电压(Max)	Pick-up voltage(Max)	75% 额定电压(Nominal voltage)											
释放电压(Min)	Drop-out voltage(Min)	10% 额定电压(Nominal voltage)											
允许最大电压(VDC)	Max allowable overdrive voltage(VDC)	130% 额定电压(Nominal voltage)											

安全认证(相关认证以第三方认证证书为准) / SAFETY APPROVAL RATINGS



E167996

10A	125VAC
10A	14VDC

外形图 / OUTLINE DIMENSIONS

单位/Unit(mm)

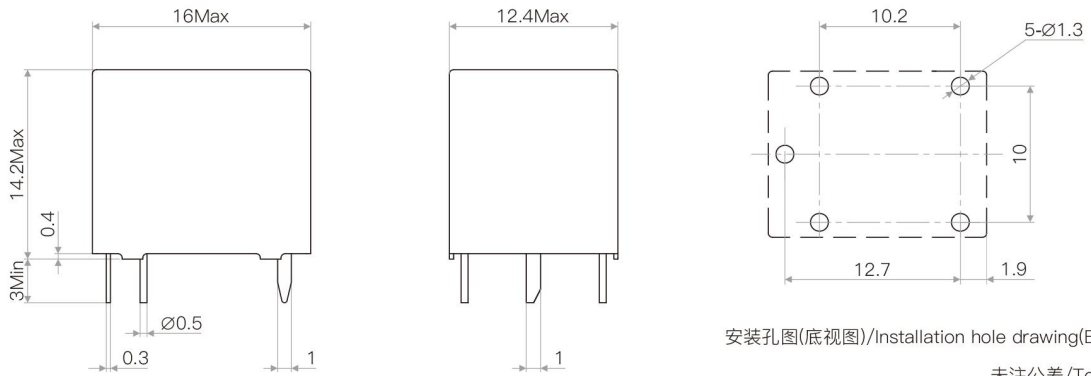

安装孔图(底视图)/Installation hole drawing(Bottom view)

未注公差/Tolerance:±0.1

线路图(底视图) / WIRING DIAGRAM (BOTTOM VIEW)

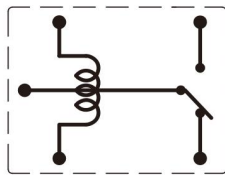

转换C型/Conversion C type

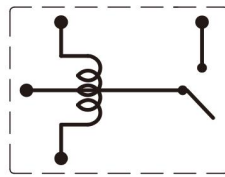

常开A型/Normally open A type

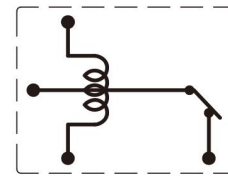

常闭B型/Normally closed B type

性能曲线图 / CHARACTERISTIC CURVES

电耐久性曲线
Electrical endurance curve

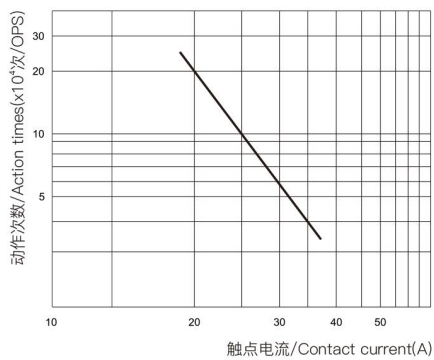

测试条件: 0.2s通, 2s断。

Test conditions: 0.2s on, 2s off.

线圈温升
Coil temperature rise

